

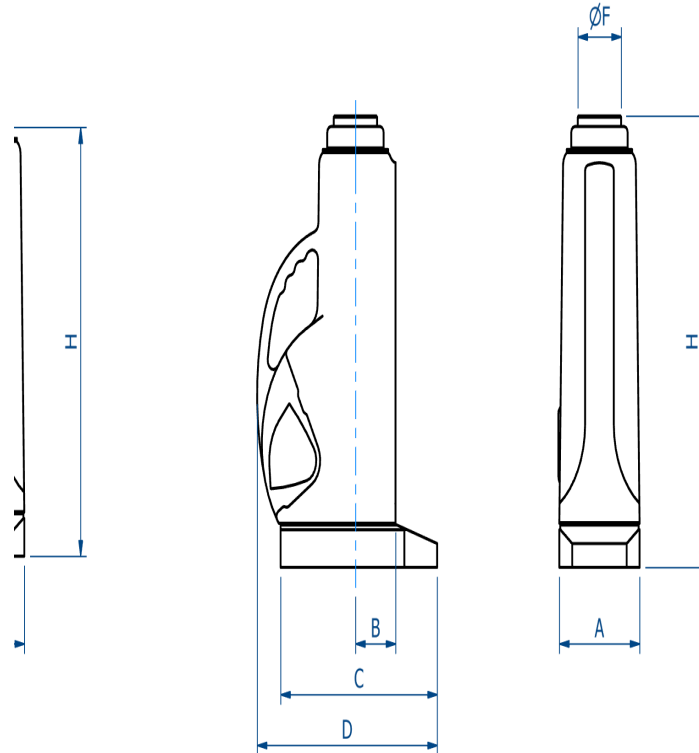

Hydralite 12" Screw Ram Jack



Product code	PS1220S		PS1230S		PS1260S	
Ram Capacity	20 Tonnes		30 Tonnes		60 Tonnes	
Lift Per Stroke	1.1 mm	0.042 ins	0.70 mm	0.026 ins	0.3 mm	0.013 ins
Weight of Jack	16.7 kgs	37 lbs	23.40 kgs	52 lbs	43.7 kgs	97 lbs
Working Pressure	682 Bars	9,900 PSI	644 Bars	9,350 PSI	644 Bars	9,350 PSI
Effort on Lever (max)	54 kgs	120 lbs	52 kgs	115 lbs	52 kgs	115 lbs
Oil Capacity	1.14 Litres	2 Pints	1.71 Litres	3 Pints	2.84 Litres	5 Pints
Dimensions	mm	ins	mm	ins	mm	ins
A - Width	121	4.75	140	5.5	190	7.5
B - Centre Ram To Face	60	2.38	70	2.75	92	3.625
C - Base Length	246	9.69	273	10.75	339	13.375
D - Overall Depth	289	11.38	311	12.25	384	15.125
F - Ram Diameter	60	2.38	76	3	108	4.25
H - Closed Height	464	18.25	479	18.875	536	21.125
Stroke	305	12	305	12	305	12
Service Kit Number	133930		133932		133935	