

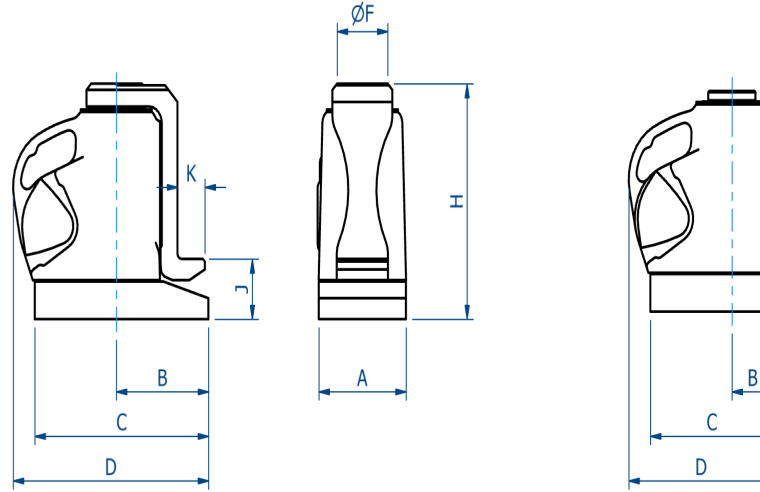

Hydralite 6" Claw Ram Jack



Product code	PS620C		PS630C		PS660C	
Ram Capacity	20 Tonnes		30 Tonnes		60 Tonnes	
Claw Capacity	8 Tonnes		12 Tonnes		24 Tonnes	
Lift Per Stroke	1.1 mm	0.042 ins	0.70 mm	0.026 ins	0.3 mm	0.013 ins
Weight of Jack	10.90 kgs	24 lbs	15.40 kgs	34 lbs	27.4 kgs	61 lbs
Weight of Claw	3.6 kgs	8 lbs	4.90 kgs	11 lbs	15.7 kgs	34.5 lbs
Working Pressure	682 Bars	9,900 PSI	644 Bars	9,350 PSI	644 Bars	9,350 PSI
Effort on Lever (max)	54 kgs	120 lbs	52 kgs	115 lbs	52 kgs	115 lbs
Oil Capacity	0.64 Litres	1.13 Pints	0.88 Litres	1.5 Pints	1.71 Litres	3 Pints
Dimensions	mm	ins	mm	ins	mm	ins
A - Width	121	4.75	140	5.5	190	7.5
B - Centre Ram To Claw	125	4.94	143	5.265	181	7.125
C - Base Length	246	9.69	273	10.75	339	13.375
D - Overall Depth	214	8.44	235	9.25	286	11.25
F - Ram Diameter	60	2.38	76	3	108	4.25
H - Closed Height	276	10.88	281	11.062	327	12.875
J - Base to Claw	67	2.63	73	2.875	73	2.875
K - Claw Depth	41	1.61	45	1.77	48	1.89
Stroke	152	6	152	6	152	6
Service Kit Number	133506		133511		133518	